

DIN 11024

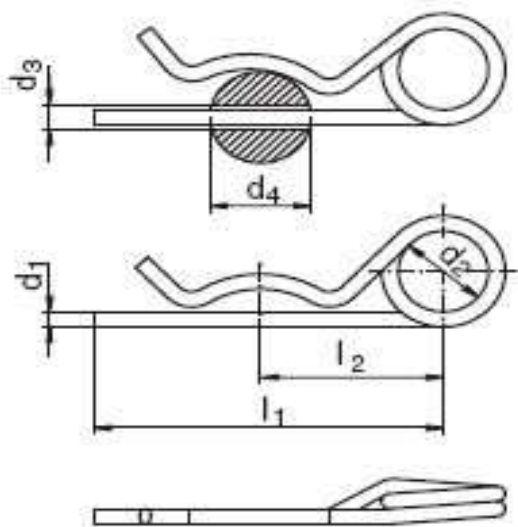

Rozdíly v rozměrech mezi normovanými položkami dle DIN 11024 a komerčními velikostmi

Springlock double - dle DIN 11024

d1 = průměr drátu	d3 = průměr díry	d2	l1	l2	d4
2,25	2,5	20	42	24	9,0-11,2
2,80	3,2	20	48	26	11,2-14,0
3,60	4,0	20	64	32	14,0-20,0
4,50	5,0	25	80	39	20,0-26,0
5,60	6,3	25	97	45	26,0-34,0
6,30	7,0	30	125	56	34,0-45,0
7,00	8,0	30	150	63	45,0-56,5

Springlock double - komerční rozměry

d1 = průměr drátu	d3 = průměr díry	d2	l1	l2	d4
2,0	2,5	10	50	25	8,0-14,0
3,0	3,5	16	62	32	14,0-20,0
4,0	4,5	23	78	44	17,0-24,0
5,0	5,5	26	92	50	18,0-30,0
6,0	6,5	30	120	70	24,0-36,0
7,0	8,0	30	130	72	24,0-40,0
8,0	9,0	30	130	76	24,0-45,0